

## **Design and Fabrication of 360° Cooler cum Heater**

**Bankar Amol Sharad, Choudhari Vishal Dilip,  
Choughule Ramesh Subhash, Kalokhe Bharat Sajan**

Mechanical Engineering, BSIOTR, WAGHOLI, Pune, India.

**Abstract:** *The evaporative cooling and forced convection heater is one of the earliest methods employed by men for conditioning their houses. Only in recent years, it has been put on sound footing thermodynamically. Evaporative cooling is a process of adiabatic saturation of air when a spray of water is made to 360 degree evaporative cooling pads without transfer of heat from or to the surroundings. Simple 360 degree evaporative cooling is achieved by direct contact of water particles & a moving air stream. If the water is circulated without a source of heat & cooling, dry air will become more humid & will drop in temperature. Simple 360° cooling is achieved by direct contact of water particles & a moving air stream. If the water is circulated without a source of heat & cooling, dry air will become more humid & will drop in temperature. In a complete contact process, the air would become saturated at WBT of the entering air.*

**Keywords:** *Evaporative Cooling, Forced Convection, Adiabatic Saturation, Dry Air, Humidity, DBT, WBT, Comfort, Relative Humidity*

### **1. INTRODUCTION**

The air may be sufficiently cooled by 360 evaporative process to results a considerable degree of summer comfort in climates of high dry-bulb temperatures associated with low relative humidity. The comfort given by the 360 cooling always depends upon the outdoor temperature and Dry bulb temperature. Low Wet bulb temperature always gives more comfort with 360° cooling. Although the 360° cooling does not perform all the function of true air-conditioning but it provides comfort by filtering & circulating the cooled air.

Before the advent of residential air-conditioning it was the only mechanical means available to make home interiors livable in the hot, dry, desert summers. 360 ° coolers function well except for the few weeks of the summer “monsoon” season with its accompanying elevated humidity and thus decreased cooler efficiency. These cooling

systems are economical in terms of energy usage. During the energy crunches of the last two decades, 360° cooler use was promoted as one means to control household utility bills. However, little thought was given to cooler water consumption. With Nagpur's rapidly increasing population, warm temperatures, and limited water supply, 360° cooler water usage can no longer be ignored.

## 2. OBJECTIVE

Energy Crisis: this A.C. consumes less electricity. It doesn't create any type of pollution so it is eco-friendly. This A.C. supplies air without increasing humidity compared with conventional air coolers. It has low operational and overall cost. It can be used in winter for heating rooms 360 direction will allow to sit people any where

## 3. METHODOLOGY

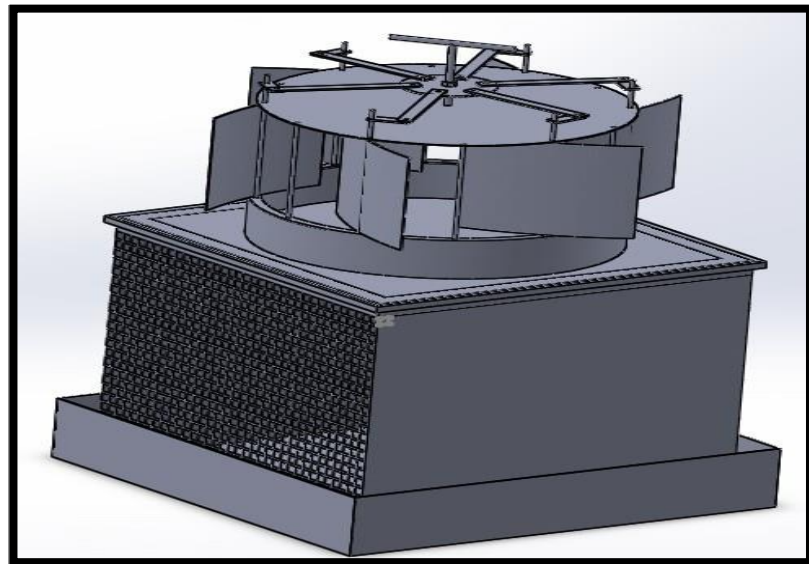

The set-up consisted of the following components:

- Exhaust Fan
- Motor
- Frame
- Cooler Body
- Water Sump

#### 4. COMPARISON WITH CONVENTIONAL COOLER

Sr.No.	Parameters	Conventional Cooler	360 degree cooler
1	Initial Temperature	30°C	30°C
2	Final Temperature	27 °C	23 °C
3	Temperature drop	3°C	7 °C
4	Time required	1.5 hr	1.5 hr
5	Speed of Fan	1300 rpm	1300 rpm

#### 5. HEATING COIL READING

Sr.No.	Parameters	
1	Initial Temperature	30°C
2	Final Temperature	33°C
3	Temperature Increased	3°C
4	Time required	1.5 hr
5	Speed of Fan	1300 rpm

#### 6. ADVANTAGES

- low cost
- high effectiveness
- permitting a wide range of applications
- Versatility in the buildings, dwellings, commercial and industrial sectors.
- They can be specially applied in dry and hot climates, as the minimum cooling temperature for the air depend on its the wet bulb temperature.
- Evaporative air coolers which are used for air-conditioning in hot and dry climates, have considerably low energy consumption compared to refrigerated systems. Because they do not need any refrigerant.
- Evaporative air coolers have another important advantage over refrigerated systems which are associated with the ozone layer depletion problem.

#### 7. DISADVANTAGE

- Water consumption associated to the operation of these systems, which is a scarce resource in dry and hot climates, where these systems best work. The reduction in electric consumption implies compensation in the global amount of water consumed. This is due to the fact that conventional power plants with an average performance.

## 8. FUTURE SCOPE

1. It works best for comfort cooling in hot and dry. EACs are widely used in the Middle East Australia, the Indian subcontinent, Eastern African, northern Mexico, and the southwestern United States.
2. IEAC can be useful in some comfort cooling applications and also for many commercial applications such as greenhouses and poultry houses.
3. It is low cost as well as low power consumption as compared to compressor based A/C system.
4. 360 design will allow person to sit in any direction.

## 9. CONCLUSION

- Comfort thermal conditions achieved in the living room. That is room temperature up to 20.7 °C and relative humidity of 52%.
- At lower cost natural cooling cabin for preservation of food has been developed. So as comparing the cost of this product with the existing products in the market is, solar product appeals better and affordable by common people. This solar product perfectly suits for villages, schools and offices and thus prevention from the power cut problems. It comprises of many attractive features such as usage of solar energy, cooler and cooling cabin at lower cost. The above method is eco-friendly and natural, electricity savers. Durability of our product is more thus minimizing the cost. No electricity is spent so this product saves the energy and saves environment from getting polluted.

## 10. ACKNOWLEDGEMENT

First and foremost, we would like to thank our guide, Prof. P.V. Jatti for his guidance and support. We will forever remain grateful for the constant support and guidance extended by guide, in making this report. Through our many discussions, he helped us to form and solidify ideas. The invaluable discussions we had with him, the penetrating question he has put us and the constant motivation, has all led to the development of this project.

We wish to express our sincere thanks to our Principal Dr. T. K. Nagraj Head of Department Dr. P. S. Kachare Project Coordinator Prof. P. V. Jatti and also grateful thanks to the our departmental staff members for their support.

We would also like to thank to our friends for listening to our ideas, asking questions and providing feedback and suggestions for improving our ideas.

## REFERENCES

- [1] O. Amer, R. Boukhanouf, And H. G. Ibrahim, 'A Review Of Evaporative Cooling'
- [2] Miss.Namrata Govekar, Mr.Akshay Bhosale, Mr.Amol Yadav, 'Modern Evaporative Cooler', Novateur Publications International Journal Of Innovations In Engineering Research And Technology [Ijiet] , Issn: 2394-3696, Volume 2, Issue 4, Apr.-2015
- [3] Akhilesh Yadav, Rajatkumar Bachchan, Sankesh Toraskar, Dattaprasad Tendolkar, Prof. Ramankumar, 'Design And Fabrication Of 360 Cooler Cum Heater', International Research Journal Of Engineering And Technology (Irjet) E-Issn: 2395-0056 Volume: 05 Issue: 05 May-2018[4] Sunil J.Kavle, Vivek M.
- [4] Shahane, Nivrutti Satpute, Vitthal N. Garje, Prof. Shrikant D Jadhav5, 'Manufacturing Of 360 Degree Rotation Air Cooler', International Research Journal Of Engineering And Technology (Irjet) E-Issn: 2395-0056 Volume: 05 Issue: 03 | Mar-2018
- [5] Rajesh Maurya, Dr. Nitin Shrivastava, Vipin Shrivastava, 'Performance Evaluation Of Alternative Evaporative Cooling Media', International Journal Of Scientific & Engineering Research, Volume 5, Issue 10, October-2014 676 Issn 2229-5518