

Smart Highway Using Renewable Sources of Energy

Prof.Pragya Sharma, Mr.Jay Pawade, Mrs. Dhanashree Lute, Mr.Ankit Sawai
Mr.Rushikesh Yadav

Department of Civil Engineering
Dr.D.Y.Patil School of Engineering, Pune, India

Abstract: *A smart highway making use of renewable sources of energy is an innovative concept used for the road that are to be designed in future for the transportation facilities for safety purpose. Nowadays safety on road is to be considered an important factor so as to minimise the rate of accident. By this system also we can make the flow of traffic smooth without having any traffic problem and provide a smart lightning system on the road .*

By making the use of renewable sources we can also consume the energy naturally. The system includes vertical axis turbine which is a hybrid system as solar panel is set up on the top of turbine with the components like GSM module, AI(Artificial Intelligence), LDR sensor, Traffic counters, Led displays.

The turbines are to be placed in the centre of road at a certain interval so as when the vehicle passes by the turbine it rotates due to the velocity flow of vehicle and also through the wind that flows naturally due to this flow the wind turbine will rotate and generate some energy and the energy which is generated will be stored in the form of battery and then will be supplied for the lightning system for traffic signal and other required purpose.

It will also help to maintain the proper safety of the road as there are various components like GSM module installed on it also sleep awakening system emergency light system are used in this system so as to provide a proper safety while travelling.

Keyword: *vertical axis turbine, GSM module, LDR sensors , sleep awakening system*

1. INTRODUCTION

Energy plays an important an important role in the economic development and also in human development. One of the basic demand of nation is energy, as with the developing technology demand for more energy makes us seek new sources for energy. Researches for renewable sources have initiated wind power first and then solar power. Efficiency of solar power is 18% and of wind power is 55%.

The main aim of this work is design and implementation of solar wind hybrid energy system. Here we made a hybrid system where the solar power is stored in battery and the combination of battery output and windpower output fed to load. Solar Power is available only for daily light as the wind power is throughout the day.

Energy Resources: Solar and Wind

Solar Energy: India receives a solar energy equivalent of 5000 trillion Kwh/year with a daily average solar energy incidence of 4-7 kwh. This is considerably more than total energy consumption of the country. Most of the country experiences 250-300 sunny days which makes solar energy a viable option in those areas.

Wind Energy: The development of wind power in India began in 1990 and has increased significantly in last few years. India has the fifth largest wind power capacity in the world

2. OBJECTIVE

- To design a smart lightning system which targets energy saving and autonomous operation on economical affordable for steets
- Build and energy saving lightning system with integrated sensors and controllers
- To provide safety
- Minimise accidents on the highways
- Making use of renewable sources

3. METHODOLOGY

In this paper it talks about the various information used for gathering the information. There are many methods used in this project such as internet references interviewing technician. In this project the technologies adopted are given below. Proper selection of material is main objective. The selection of material depends on following factors:

- Availability of material
- Cost of material
- Mechanical properties of material
- Suitability of material
- Physical properties of material.

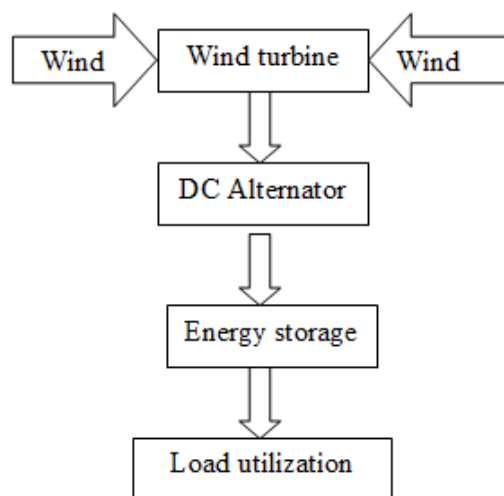

Fig 1: Block diagram of wind turbine

Base dimension	Blade dimension	Shaft dimension	Pulley Dimension
Height =111.6cm	Height =73cm	Diameter =2.54cm	Diameter =28cm
Width =91.44cm	Diameter =122cm	Length =91.44cm	Hole diameter=2.54cm
Breadth =122cm	Thickness =0.1cm		
	Angle =45 ⁰		
	Angle b/w blades =60 ⁰		

Table No1: Specification of wind turbine

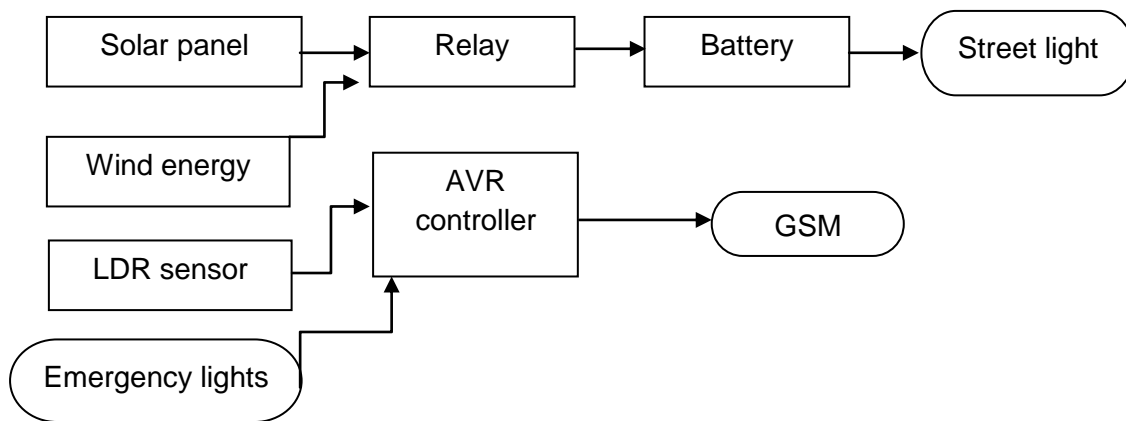

Fig 2: Block diagram of hybrid system

3.1 EMERGENCY LIGHTS: The emergency vehicles are spark light of vehicle. The emergency lights are switched on as soon as the automatic break starts to function. The signal warns the driver from approaching the rear end of vehicle and make the driver cautious and hence avoid the chances of collision.

3.2 WIND TURBINE: A wind turbine is device that converts kinetic energy from wind into the electrical power. The technical description for this type of machine is an aerofoil-powered generator. The small turbines are used for application such as battery charging for devices , to power the traffic signs, warning signs.

3.3 RELAY: The relay is used as the connector between solar panel, wind and battery.

3.4: SLEEP AWAKENING SYSTEM: In this system the main function is the vibrator. The main function of this system to keep the driver awakens by producing vibration. The vibrator motor is switched on when the car is in halt position. The motor here used is a D.C motor.

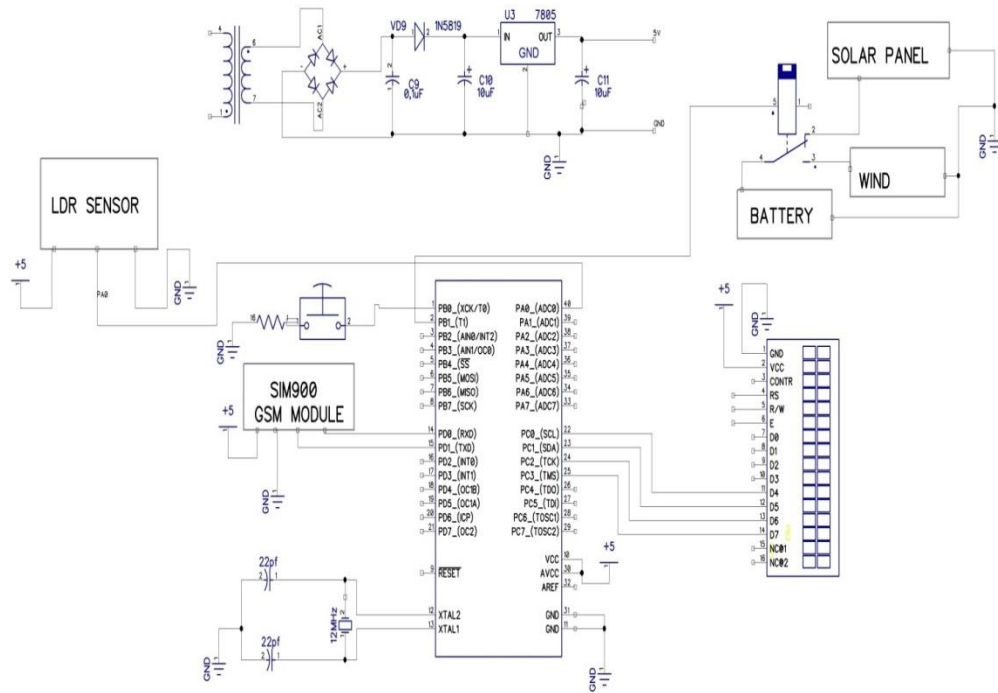

Fig 3: Circuit diagram of hybrid system

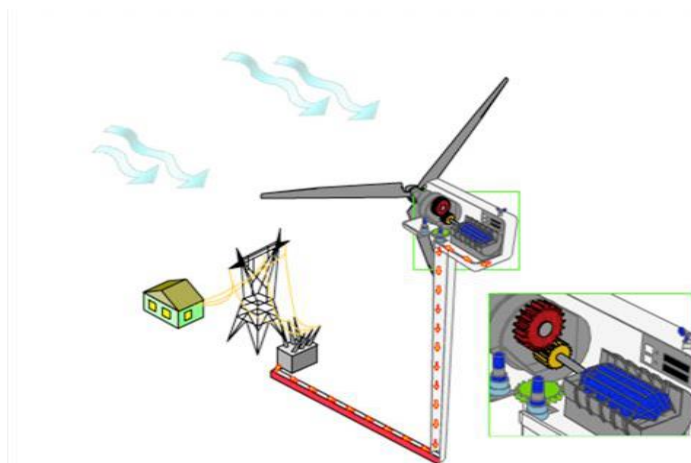

Fig 4: Vertical axis wind turbine

4. CONCLUSION

Even if we are unable to implement all this components of the smart highway at the moment, many of the elements like LED lights on the bottom edge of highway , portable compressor, charging station can be used on roads in area where a reliable source of electricity is unavailable. Adding these small, inexpensive components would be relatively easy to add in developing nations where they are seeing more and more drivers on the road but lack of infrastructure. Who knows if this is what our highways will look like tomorrow or after 2-3 years from now or if this idea will turn into something bigger. Maybe over highway in our not so distant future will able to sustain itself, paving a way to a greener and more environmentally conscious future.

ACKNOWLEDGEMENT

Apart from these efforts of me, the success of any project depends largely on the encouragement and guidance of many others. I take this opportunity to express my gratitude to people who have been instrumental in the successful completion of the B.E. project.

I would like to take this opportunity to express my deep sense of gratitude towards my guide **Prof. P.Sharma**, for this expert guidance, support and encouragement throughout the work.

I would like to thank **Prof. S.M. Karodpati (H.O.D. Civil Engineering Dept)** for his constant support and providing me with all possible facilities in the department. I admire his thoughtfulness towards student and extremely thankful for the same.

I would also like to thank all staff member of Civil Engineering Department & my friends who directly or indirectly helped me successful completion of this project

REFERENCES

- [1]. Reza Mohamaddoust , AbolfazlToroghiHaghighat, MohamadJavadMotahari Sharif and NiccoloCapanni, "A Novel Design of an Automatic Lighting Control System for a Wireless Sensor Network with Increased Sensor Lifetime and Reduced Sensor Numbers", *Sensors* (2011), Volume No. 11(9), pp. 8933-8952.
- [2]. De Dominic is, C.M.; Flammini, A. Sisinni, E.; Fasanotti, L.; Floreani, F.; "On the development of a wireless self localizing streetlight monitoring system ", *Sensors Applications Symposium IEEE*, pp. 233 -238, 2011.
- [3]. Gustavo W. Denardin, Carlos H. Barriquello, Alexandre Campos, Rafael A. Pinto, "Control Network for Modern Street Lighting Systems", *IEEE symposium on Industrial Electronics (ISIE)*, (2011), pp. 1282 –1289.
- [4]. Jing Chunguo, Wang Yan Sun, Wenyi Song, "Design of Street Light Pole Controller Based on WSN", *The Tenth International Conference on Electronic Measurement & Instruments, ICEMI* (2011), pp. 147 –150.
- [5]. Shentu, Xudan; Li, Wenjun; Sun, Lingling; Gong, Siliang, "A new streetlight monitoring system based on wireless sensor networks", *International Conference on Information Science and Engineering*, pp. 6394 –6397,
- [6]. Wu Yue; Shi Changhong; Zhang Xianghong; Yang Wei; "Design of new intelligent street light control system ", *8th IEEE international Conferences on Control and Automation (ICCA)*, (2010) , Page(s): 1423
- [7]. S. Georges, F. H. Slaoui "Case Study of Hybrid Wind-Solar Power Systems for Street Lighting "- *21st International Conferences on Systems Engineering*2011
- [8]. S. Ramkumar, V. Sumathi M.E "Implementation of Reduced Switch Modular Inverter for Hybrid of Solar Photovoltaic and Wind Energy System" - *International Journal of Scientific and Research Publications*, Volume 3, Issue 2, February 2013 1 ISSN 2250-3153.
- [9]. Habib M.A., Said S.A.M., El-Hadidy M.A. and Al-Zaharna. 1999. Optimization procedure of hybrid photovoltaic wind energy system. *Energy*. Vol. 24, pp. 919-929.
- [10]. Total amount of human death per year collected from <https://interestingengineering.com> Accessed on 13/07/2018