

## ALCOHOLE DETECTION AND SEAT BELT CONTROL SYSTEM

P.S.Dhayarkar, S.B.Shelke, A.D.Shelar, S.D.Kamble

Dept.Of Computer Engineering, Bhivrabai Sawant Polytechnic  
Pune , India

**Abstract:** *On a survey that has been done recently, said that nearly 70% of road accidents occur due to drunken drive, with a range of 44% to 67% in small cities. They also conveyed that overall of 56 accidents and 14 to 15 deaths occur on our roads per day due to not wearing the seat belts. In the already available system, the alcohol sensor is kept on the car steering and thereby controls the vehicle according to the presence of alcohol. But road safety is indeed important in other aspect that is the reason we are controlling the system based on the seat bealt wearing.*

**Keywords:** *IR Sensor, relay, engine/motor, AurdinoIDE, Frizing, GSM, Microcontroller*

### 1. INTRODUCTION

In recent epoch, there happens to occur lot of road accidents due to drunken driving and rash driving. Boulevard safety has become one of the major concerns in today's life. Drinking and driving is already a serious public vigor problem, which is likely to emerge as one of the most noteworthy problems in the near prospect [1]. Not only drunken drive, but also driving rudely without wearing seat belts in cars causes a lot of tragic lethal deaths. Seat belt is one among the key safety measure used in vehicles like cars to avoid major injuries to the driver driving the vehicle [2]. Advanced life saving measures, such as electronic constancy control, also show momentous undertake for reducing injuries, e.g., crash analysis reports proves that more or less 34% of tragic traffic accidents could have been prevented with the use of electronic constancy control [3]. Due to driver carelessness there occur to demand chief road accidents within the city, but outside the city, accidents mostly occur due to drunken driving [5]. Presently, there transpire diverse technologies to reduce individual work and time intricacy. Micro controller is one such thing, which is defined to be a small chip or incorporated circuit that can be programmable to function the peripherals connected to it. Arduino is one kind of micro controller which can be easily operable. Arduino micro controller

is an open source micro controller from which there is no response present in the micro controller [6]. The proposed system aims at reducing the road accidents and fatal deaths due to drunken and rash driving. The system looks for the presence of alcohol consumption of the driver and locks the ignition if positive. The lock on the car ignition is released. The driver has worn seatbelt. The updates of the car start and its progress are recorded and notified to the particulars via GSM. Global System for Mobile communications (GSM) is the most prominent wireless calibre for mobile phones in the world. The broadcast of Short message service (SMS) in TEXT mode and PDU mode is carried out by GSM [4]. The wireless technologies are also concluded using cloud technologies with the help of soft computing techniques [5]. Since the realm of our application is based on embedded systems, which is devoted to peculiar tasks, delineation developers can optimize it reducing the expanse and fare of the product and increasing the consistency and performance [7]. The existing system provides an environment where the driver cannot start the ignition when the driver is drunk above the verge value.

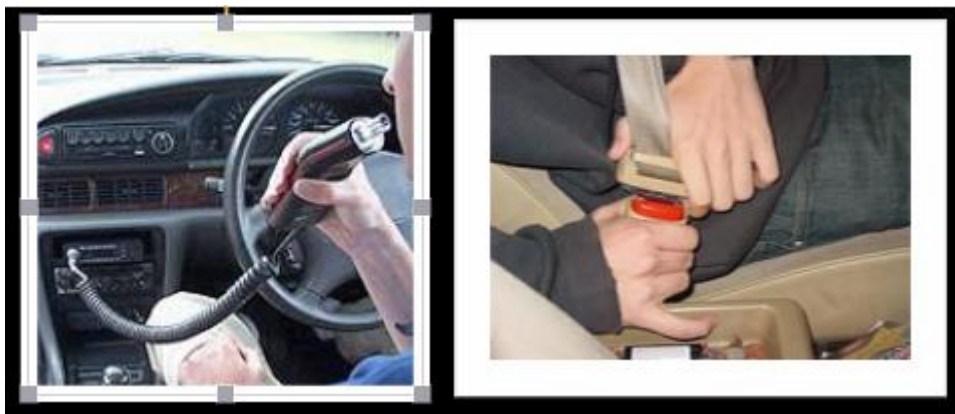

**Alcohol Sensor**

**Seat belt Sensor**

## **2. LITERATURE SURVEY**

In this paper, there are only limits provided to the speed limitation and alcohol detection but there is no more security about the owners of those cars or buses. In the previous published paper, there are only speed limit and alcohol detection by the Arduino. In 2016, unrestrained passenger vehicle occupant fatalities increased by 4.6%, from 9,968 to 10,428. Among passenger vehicle occupants killed in 2016, almost half (48%) were unrestrained. Seat belt use in 2017 dropped to 89.7% down from 90.1% in 2016. MAP-21 modified US code to permit seat belt interlocks of compliance option.

Paper Name	Author Name	Proposed System	For this paper we referred
International Journal of advanced Research in Electrical and Instrummentation Engg	S.V.Altaf, Suggala Abhinaya	In this paper, they have research on the speed limit Or speed control and alcohole detection system And locking system	In this paper, we have referred the solution to the Alcohole detection and Seat belt systm ,checking message and Goes message to the Owner
International Journal of Scintific and reserch Publication	Priyal.N.Sheth, A.D.Badgujar	In this paper,focused on seat bealt controll system and Speed accordingly to avoid fata injuries	In this paper, we have referred how plan the security of the people by using SMS system
Ferguson International LLC	Susan A.Ferguson, Eric Traube	In this paper, discussed the basics of the Alcohole Detection system	In this system we have referred if we want to save our environment form an acident then all types of saftyes are essential.
NHTSA's Research paper	NHTSA's	Using seat belt control system it shows how may peoples ahe dead becuse of seat belt And drink drive	In this paper there is no more security

**DISADVANTAGES:** System doesn't provide the other security.

**ADVANTAGES:**

- This circuit detects the alcohol directly.
- High accuracy.
- Circuit contruction is simple.
- High safer.

### 3. PROPOSED SYSTEM

In this project,we are going to introduced alcohol sensor and seat belt sensor, microcontroller relay for controller and GSM model to provide an automatic message to the owner of the cars and other vehicles as well.

#### 4. SYSTEM ARCHITECTURE

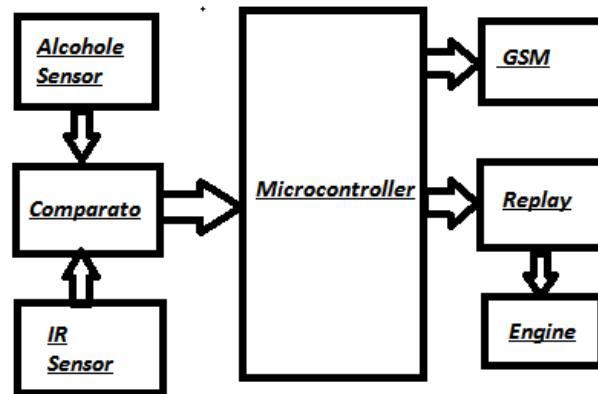

*..System architecture..*

#### 5. CONCLUSION

Seat belt as a safety feature reduces chances of major injuries or even loss of life in an accident, hence to make sure that people wear seat belt; Driver Assistive Safety System has been proposed. Considering type of traffic prone to accident, two mode of Driver Assistive Safety System have been devised. Alcohol is not an ordinary commodity. While it carries connotations of pleasure and sociability in the minds of many, harmful consequences of its use are diverse and widespread. From a global perspective, in order to reduce the harm caused by alcohol, policies need to take into account specific situations in different societies. Average volumes consumed and patterns of drinking are two dimensions of alcohol consumption that need to be considered in efforts to reduce the burden of alcohol-related problems. Avoiding the combination of drinking and driving is an example of measures that can reduce the health burden of alcohol. Worldwide, alcohol takes an enormous toll on lives and communities, especially in developing countries and its contribution to the overall burden of disease is expected to increase in the future. Particularly worrying trends are the increases in the average amount of alcohol consumed per person in countries such as China and India and the more harmful and risky drinking patterns among young people. National monitoring systems need to be developed to keep track of alcohol consumption and its consequences, and to raise awareness amongst the public and policy-makers. It is up to both governments and concerned citizens to encourage debate and formulate effective public health policies that minimize the harm caused by alcohol.

#### REFERENCES

- [1] Fatality Analysis Reporting System (FARS), June 2009, [online] Available: <ftp://ftp.nhtsa.dot.gov/fars/>.
- [2] International Review of Applied Engineering Research, Research India Publications, vol. 4, no. 4, pp. 349-354, 2014, ISSN 2248-9967.
- [3] A. Lie, C. Tingvall, M. Krafft, A. Kullgren et al., The effects of automatic emergencybrking on fatal and serious injuries, 2006.