

Child Tracking System

**Deepti Singh, Neha Patil, Snehal Shirke, Vaishnavi Wadghule,
Prof.Vijay Sonwane**

Computer Department ,JSPM's BSIOTR, Wagholi, Pune, Maharashtra

Abstract: *Now a days lots of cases seen of missing Childs. The Childs are missing have ages between 14 to 17. Parents are worried about children. The system explains about an android application which is used to track the missing children. Nowadays lots of mobile phone users have an android phone. The application works with the help of android mobile. The android application based on GPS and SMS services in Android mobile. The GPS service is used for tracking exact location of Child. The GPS and GSM based systems are used to track the location of Child.*

There are two ways that can a application works. First is GPS based that is related to the Location services and second is SMS based which is related to the Network services. If Location based services not working then the application uses Network based services which can be able to send and receive messages. Initially the GPS continuously takes input data from the satellite and stores the latitude and longitude. With the help of propose system we can track our mobile. In propose system if we want to track mobile location then we need to send a message to our device, by which it gets activated. Once application gets activated it takes the current latitude and longitude positions values from the GPS and sends a mail to the particular email id which is predefined at registration. Propose system could be used to track children current location.

Keywords: - Global Positioning System (GPS), Short Messaging Service (SMS), Global System for Mobile Communications (GSM), Network Services, Android.

1. INTRODUCTION

With changing times, the mobile technology has changed a lot and in the last few years we have seen the arrival of various new kinds of gadgets in the form of Smartphone, camera-phone, Android and tablet phones. In fact, the handset industry has turned from simple budget handsets to ultramodern high end mobile phones. Today's device is almost

everything it is fashionable, innovative, appealing, high-performing, durable, stylish and multitasking. Latest gadgets can be used for various purposes like browsing mobile, internet, playing games, emailing, and blogging, messaging, GPS, YouTube, Google search, Gmail and more.

The Global Positioning System (GPS) is a location system based on a constellation of 24 to 32 satellites orbiting round the earth at altitudes of 11,000 miles. Each satellite is powered by the Sun via its solar panel. In its earlier years, GPS was developed in the US for military use, for the Department of Defense (DOD). Through the years of development and improvement, we have advanced the use of GPS to tracking our precise location worldwide and as a navigation aiding tool for civilian usage. Currently, it is used as navigation tool device to assist us in finding the shortest route to our destination. We can use GPS to find lost mobile phone or parents can track to their children location.

2. MOTIVATION

- Parents can track to their children location.
- We can use GPS to find lost mobile phone.
- It ensures Safety of our Children and Mobile Phones.

3. PROBLEM STATEMENT

To provide a Android app which will track children's location for parents and also locate our mobile phones if we lost or forget it somewhere using C4.5 Algorithm and Android Technology.

4. EXISTING SYSTEM

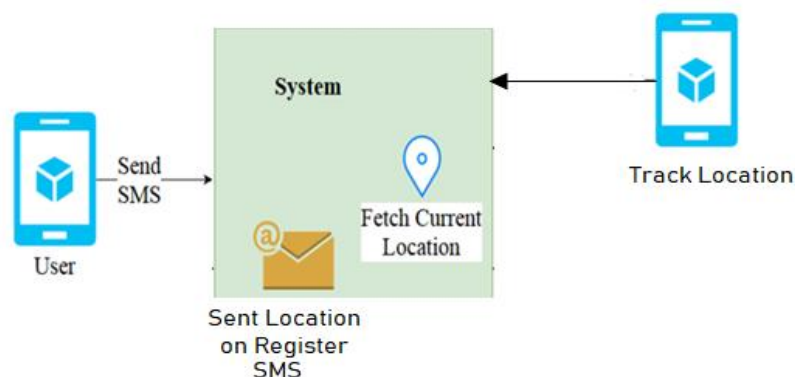

Fig.1: Existing System Modules

5. METHODOLOGY

In propose system user will have main 3 options to find or track their mobile location. If user forget their mobile in home then user will send preformatted SMS to their phone then mobile will start ringing. If user forgot their phone outside of home then he can track by propose system.

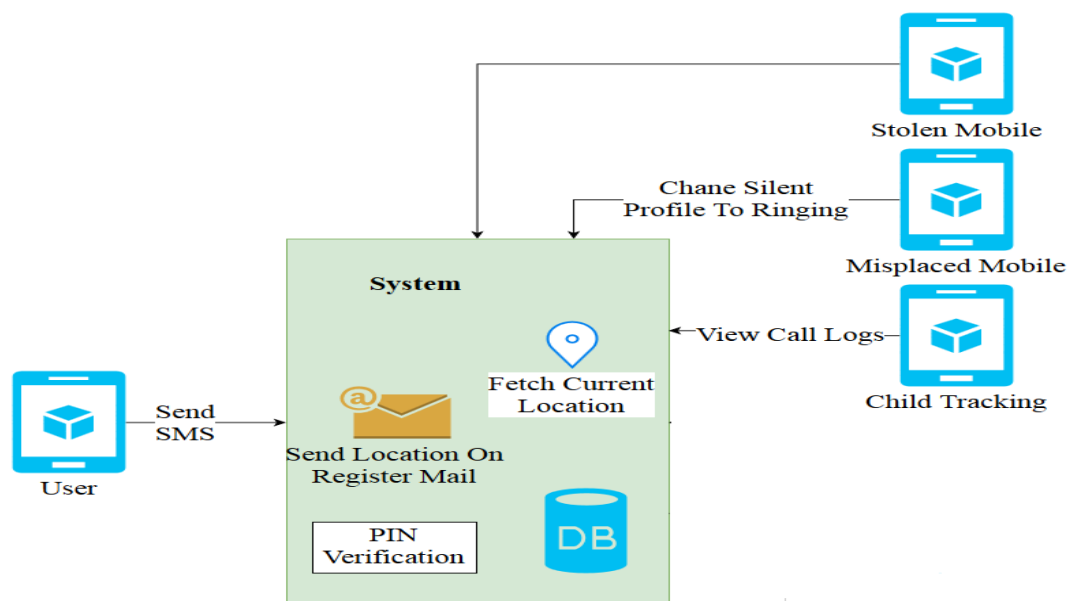

Fig.2: Proposed System Modules

6. PROJECT MODULES

a) Stolen Mobile Detection

In this case user will send SMS on stolen mobile in predefined format with PIN. System will fetch current location and capture photo from front and back camera. This information then sends to register email id.

b) Misplaced Mobile Detection

In this case user will send SMS on misplaced mobile in predefined format with PIN. System will change silent profile to general profile also system will fetch current location and capture photo from front and back camera. This information then sends to register email id.

c) Child Tracker

In this case parent will send SMS on child's mobile in predefined format with PIN. System will fetch current location and capture photo from front and back camera. This information then sends to register email id. Parent also can check children's call logs.

7. LOW BATTERY ALERT SYSTEM

Low battery alert system works when the child battery is below certain amount or percentage it sent an alert message to the parent's mobile phone that the child phone battery is low.

8. ALGORITHMS USED

C 4.5:

- The C4.5 algorithm is used in Data Mining as a Decision Tree Classifier which can be employed to generate a decision, based on a certain sample of data (univariate or multivariate predictors).
- So, before we dive straight into C4.5, let's discuss a little about Decision Trees and how they can be used as classifiers.
- This algorithm is having capability to converts datasets into trees and forming a decision rules .In decision tree, there are several attributes such as nodes and leaf nodes. The leaf node represents the class, and the decision node represents the branch and sub tree for each output according to the value that has been obtained.
- The shortest route search is a problem that is discussed, with transportation being one example. In the case of transportation, the shortest route selection plays an important role. Line selection is not only about how long the road we take, but also other supporting factors. One of them is how crowded the road will be used.

9. APPLICATIONS

The application will deal with the Android platform and is utilized for GPS following between different mobile devices. The application is mindful to keep track the location of the device. The parent or child account can be edit by parents. The application will include the route history trace where the parent track for the route their child traversed during a certain period of time. The application in the device will update the location of the child to the application by having the interval time for 30 min, 1 hour and 2 hour. Parent can select the interval time to view the current location of the child. Parent also can make call from the application if any inconvenience happens when the location not found or track.

10. CONCLUSION & FUTURE SCOPE

Propose system is anti-theft mobile tracking application. This application provides strong security to Smartphone when it is lost or stolen by thief. It gives the location as well as photos of thief to user one mails id provided by user Parents can easily track their children's locations. However, with the child tracking app, parent can track and monitor their child with just a simple app. The parent is not possible to always stay beside of children as most of the parents needs to go for work. By having this child tracking system, parents can track the location of their children. In order to avoid the kidnapping cases, the child tracking system is needed.

Android is now stepping up in next level of mobile internet. There are chances of android mobile sales becomes way more than iPhone in next current years So this system is useful Android is the most used technology of our current time, which is in process to use in cars ,watches and also android TV There Are most of chances of android may become the widely used operating system in world.

REFERENCES

- [1] C. Kitts and M. Egerstedt, "Design, control, and applications of realworld multirobot systems," *IEEE Robot. Autom. Mag.*, vol. 15, no. 1, p. 8, Mar. 2008.
- [2] J. Cashbaugh and C. Kitts, "Optimizing sensor location in a multisensory single-object tracking system," *Int. J. Distrib. Sensor Netw.*, vol. 11, no. 7, pp. 1–15, Jul. 2015.
- [3] P. Corke et al., "Experiments with underwater robot localization and tracking," in *Proc. IEEE Int. Conf. Robot. Autom.*, Rome, Italy, 2007, pp. 4556–4561.
- [4] S.Wen, Z. Cai, and X. Hu, "Constrained extended kalman filter for target track- ing in directional sensor networks," *Int. J. Distrib. Sensor Netw.*, vol. 11, no. 5, pp. 1–13, May 2015.
- [5] R. R. Nair, L. Behera, V. Kumar, and M. Jamshidi, "Multisatellite forma- tion control for remote sensing applications using artificial potential fields and adaptive fuzzy sliding mode control," *IEEE Syst. J.*, vol. 9, no. 2, pp. 508–518, Jun. 2015.
- [6] J. Curcio et al., "Experiments in moving baseline navigation using autonomous surface craft," in *Proc. OCEANS, Washington, DC, USA, 2005*, pp. 730–735.
- [7] A. Bahr, J. Leonard, and M. Fallon, "Cooperative localization for autonomous underwater vehicles," *Int. J. Robot. Res.*, vol. 28, no. 6, pp. 714– 728, Jun. 2009.
- [8] A. Bahr, J. Leonard, and A. Martinoli, "Dynamic positioning of beacon vehi- cles for cooperative underwater navigation," in *Proc. IEEE Int. Conf. Intell. JSPM's BSIOTR CS DEPT 36*