



Archives available at journals.mriindia.com

International Journal on Advanced Computer Engineering and Communication Technology

ISSN: 2278-5140

Volume 15 Issue 01, 2026

Boosting Electric Vehicle Charging Performance with Hybrid and Intelligent Methods

¹Sonia Raj S. S., ²Dr. T. S. Sivarani

¹PG Scholar, Department of EEE, Arunachala College of Engineering for Women Manavilai, Vellichanthai

²M.E., Ph.D., HOD of EEE Department, Arunachala College of Engineering for Women Manavilai, Vellichanthai

Email: ¹soniarajss2002@gmail.com

Peer Review Information	Abstract
<p><i>Submission: 08 March 2026</i></p> <p><i>Revision: 26 March 2026</i></p> <p><i>Acceptance: 05 April 2026</i></p> <p>Keywords</p> <p><i>Electric Vehicle, Photovoltaic, Safety, Charging System, Battery Storage System, Efficiency</i></p>	<p>Abstract</p> <p>Electric vehicles (EVs) are becoming a vital part of modern transportation, demanding efficient and intelligent charging strategies to meet growing energy and environmental challenges. This study proposes a hybrid EV charging system that combines renewable energy sources, battery storage, and grid power, managed intelligently using a Fuzzy Logic Controller (FLC). The proposed FLC-based system dynamically adjusts charging power according to factors such as the vehicle's state of charge (SoC), grid load, energy price, and renewable energy availability. By applying fuzzy inference, the controller effectively handles uncertainties, non-linearities, and real-time variations in energy supply and demand, ensuring smooth and optimal charging performance. The integration of hybrid energy sources with intelligent fuzzy control enhances system flexibility, reduces grid dependency, and increases renewable energy utilization. Simulation and analysis results show that the proposed method significantly improves charging efficiency, minimizes energy losses, and shortens charging time while maintaining system stability and battery safety. Overall, this hybrid intelligent approach demonstrates a reliable and sustainable pathway to boost EV charging performance, supporting the development of smart and eco-friendly transportation infrastructure. The proposed strategy is validated through simulation using MATLAB 2021a /Simulink software.</p>

Introduction

The global transition towards sustainable transportation has accelerated the adoption of electric vehicles (EVs), which plays a vital role in reducing greenhouse gas emissions and dependency on fossil fuels. As the number of EVs continues to grow, the demand for efficient and reliable charging infrastructure has become increasingly important. However, the integration of large-scale EV charging into existing power systems presents significant challenges, including increased peak demand, grid instability, and fluctuations in electricity pricing. These challenges highlight the need for advanced energy management strategies

capable of ensuring optimal utilization of available energy resources while maintaining grid stability and minimizing operational costs. Hybrid EV charging systems offer a promising solution by integrating multiple energy sources such as renewable power, battery energy storage systems (BESS), and the conventional utility grid. This combination enables flexible energy sharing, improved power quality, and reduced dependency on the grid during peak hours. Renewable energy sources like solar and wind can be efficiently utilized to charge EVs, while BESS provides backup energy during low-generation periods. However, the intermittent and unpredictable nature of renewable energy

introduces complexity in power balancing and control. Therefore, intelligent control mechanisms are required to manage these hybrid systems effectively, ensuring consistent and optimal performance.

Among various intelligent control techniques, the Fuzzy Logic Controller (FLC) stands out for its ability to handle uncertainties, nonlinear behaviors, and multi-variable decision-making without requiring an accurate mathematical model. By using linguistic rules and fuzzy inference, the FLC dynamically adjusts charging parameters such as charging rate and energy source selection based on real-time inputs like state of charge (SoC), grid load, energy price, and renewable availability. This intelligent and adaptive approach not only enhances charging efficiency and battery health but also minimizes grid stress and operational costs. Consequently, integrating fuzzy logic control with hybrid energy systems presents a powerful strategy to boost EV charging performance, promoting the development of smart, sustainable, and intelligent transportation infrastructure.

A hybrid electric vehicle (EV) charging system combines multiple energy sources such as renewable power generation, battery energy storage systems (BESS), and utility grid supply to create a flexible and efficient energy management framework. This integration allows for optimized power distribution, improved energy efficiency, and reduced dependency on the grid during peak demand periods. Renewable energy sources like solar and wind can provide sustainable power for EV charging, while the BESS serves as an energy buffer to store excess generation and supply it when renewable output is low. Such hybrid configurations not only improve energy reliability but also reduce the carbon footprint associated with conventional grid-based charging systems.

To manage the complex and dynamic nature of hybrid systems, intelligent control techniques are essential. These techniques enable real-time coordination among various energy sources, taking into account factors such as load demand, renewable availability, and grid conditions. Among the available intelligent control methods, the Fuzzy Logic Controller (FLC) has emerged as an effective solution due to its capability to handle system nonlinearities and uncertain conditions. Unlike conventional controllers, FLCs do not rely on precise mathematical models; instead, they use linguistic rules and fuzzy inference mechanisms to make flexible and adaptive control decisions, ensuring stable and reliable system performance under varying operating conditions.

The application of a Fuzzy Logic Controller (FLC) in hybrid electric vehicle (EV) charging systems introduces an intelligent and flexible approach to energy management. By continuously monitoring key factors such as the vehicle's state of charge (SoC), grid load, electricity pricing, and renewable energy availability, the FLC dynamically adjusts charging parameters in real time. This ensures that energy utilization is optimized based on current conditions, promoting efficiency and reducing unnecessary strain on the grid. The adaptive nature of FLC enables it to integrate various energy sources such as solar, battery storage, and utility supply seamlessly to maintain stable operation and prevent energy wastage.

Unlike traditional control methods that rely on fixed algorithms and rigid thresholds, the FLC can effectively handle uncertainties and nonlinear behaviors in charging systems. This intelligent adaptability not only enhances charging stability but also minimizes power losses and extends battery life by preventing overcharging or rapid current fluctuations. By leveraging fuzzy inference and hybrid energy integration, the system ensures optimal utilization of renewable energy sources such as solar and wind while minimizing stress on the utility grid. This intelligent coordination enables dynamic power sharing between renewable inputs, battery storage, and grid supply based on real-time demand. As a result, it significantly improves overall charging efficiency, reduces operational costs, and maintains system stability even during variable energy conditions. The adaptive decision-making capability of the FLC allows the system to respond quickly to changes in load or energy availability, ensuring reliable and consistent charging performance.

In addition to improving efficiency, this approach contributes to the longevity and safety of EV batteries by preventing issues such as overcharging and excessive current flow. The reduced charging time and enhanced energy distribution not only improve user convenience but also promote sustainable energy use. By prioritizing renewable energy consumption and reducing reliance on conventional grid power, the integration of the FLC supports environmental goals and aligns with the growing vision of smart, green mobility. Thus, this eco-friendly and intelligent control method stands as a forward-looking solution for future EV charging infrastructure.

Proposed Methodology

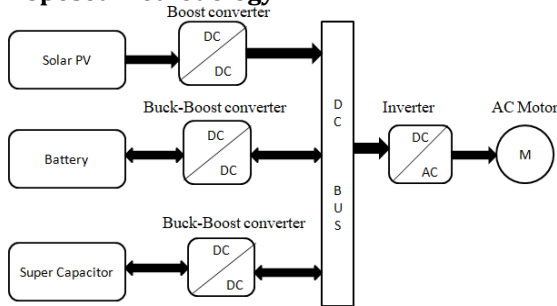

Fig 1: Block diagram of proposed work

Figure 1 shows the proposed diagram illustrates a hybrid energy system where solar PV, a battery, and a supercapacitor are integrated through DC-DC converters to a common DC bus that supplies an AC motor via an inverter. The solar PV is connected through a boost converter to raise its voltage to the DC bus level, while the battery and supercapacitor are interfaced using bidirectional buck-boost converters to enable both charging and discharging. The battery provides sustained energy for normal operation, and the supercapacitor supports fast transient power demands, reducing stress on the battery. The common DC bus ensures effective power sharing among sources, and the inverter converts DC power into AC to drive the motor efficiently and reliably.

1. A PV Array Module2

Solar power is harnessed using Solar Photovoltaic (PV) technology that converts sunlight (Solar radiation) into electricity by using semiconductors. When the sun hits the semiconductor within the PV cell, electrons are freed and bus bars collect the running electrons which results in electric current.

A PV system consists of multiple modules connected in series and parallel to increase voltage and current. Under partial shading conditions, bypass diodes cause the P-V curve to exhibit multiple local and global maximum power points while preventing hot spots by allowing current to bypass shaded modules.

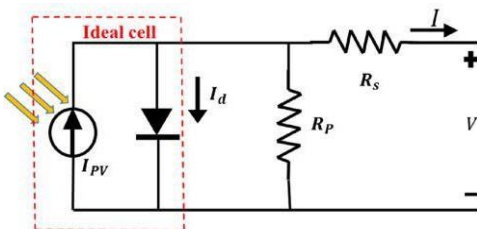

Fig 2: Equivalent of PV module

The output in the form of current is given by Eq. (1)

$$I = I_{pv} - I_0(\exp(V + R_s I / R_s) - 1) - V + R_s I / R_s \quad (1)$$

The following definitions pertain to the symbols used in the model:

I_{PV} : PV source current;

R_s : The total resistance caused by all the elements in the course of a current should be as minimal as possible;

R_p : to depict the leakage out across P-N junction, that should ideally be as wide as feasible;

I : difference between both the diode current I_D and the photocurrent I_{pv}

When T is the temperature coefficient and G is the irradiation level, equations (2), (3), and (4) are used to calculate the PV cell current, saturation current, and thermal voltage.

$$I_{pv} = (I_{pv,n} + K_1(T - T_n))G / G_n \quad (2)$$

Saturation current is given as,

$$I_0 = (I_{SC} + K_1(T - T_n)) / \exp(V_{oc} + K_v(T - T_n) / aV_t) - 1$$

(3)

Thermal voltage is given as,

$$V_t = N_s K T / q \quad (4)$$

PV systems are made up of a grid of PV cells. Current I is improved by the parallel cell combination while voltage V is added by the series cell arrangement. The number of parallel cells is N_p , whereas the number of series cells is N_m . Eq. (3.1) is transformed into Eq. (5).

$$I = N_p I_{pv} - N_p I_0 (\exp(V + R_{seq} I / N M V T a) - 1) - V + R_{seq} I / R_{peq} \quad (5)$$

It is a non-rechargeable power source, therefore a uni-directional DC-DC boost converter has been used which is responsible for voltage regulation between DC bus and FC according to the load current. This converter contains a single insulated gate bipolar transistor having switch S_1 , high frequency inductor L_2 with an internal resistance R_1 and an output capacitance C_0 .

Table 1: Parameters specification of the solar array

ITEM	SPECIFICATIONS
Maximum power	150W
Module efficiency	11.7%
Open circuit voltage	41.8%V
Short circuit current	505 A
Width	1250mm
Length	1250mm
Thickness	35mm
Weight	15.5kg

2. Mathematical Modelling Of The System

The mathematical model of the system is represented by dynamical equations. Energy management and control unit has been designed in such a way that it ensures the efficient working of the vehicle.

Solar PV was the main working sources; battery will dominate whenever solar PV has low SoC. However, the peak load current is managed by SC such as providing the initial peak current to start the vehicle and the current required for acceleration. The electric circuit diagram of HESS is shown in Fig. 3.

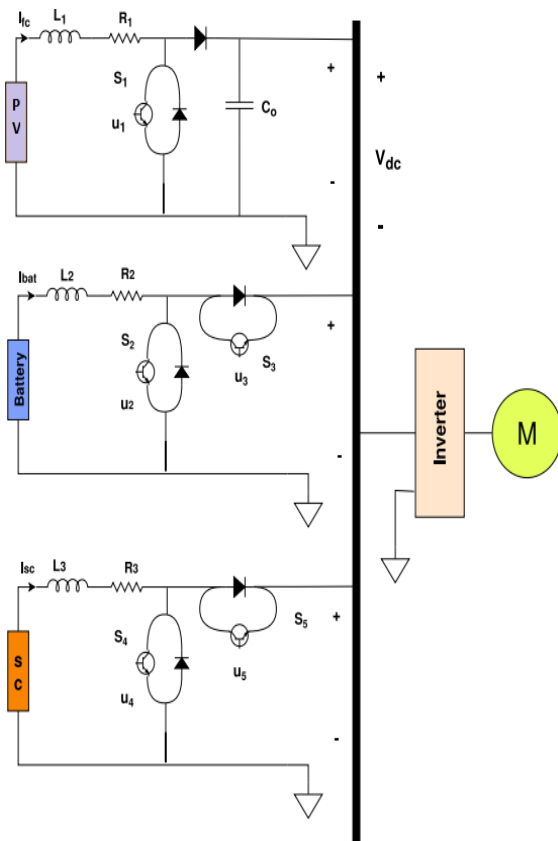

Fig 3: Circuit diagram of power sources used in PV-EV.

The Energy Management System (EMS) actively Manages the charging process of electric vehicles (EVs) by dynamically distributing power to minimize peak demand (peak shaving), while always avoiding grid overloads—this guarantees constant grid stability and cost-effectiveness.

3. Fuzzy Logic-Based Energy Management Unit

Control design without an effective energy management system might lead the system towards instability if the power distribution amongst sources is not properly managed under varying load demands. Therefore, a fuzzy logic

based energy management unit (EMU) has been proposed for the generation of the reference currents for battery and SC according to their SoC and the load requirements as shown in Fig. 4. This unit has 3 inputs and 2 outputs along with 36 rules to determine the battery and SC reference currents under different load requirements.

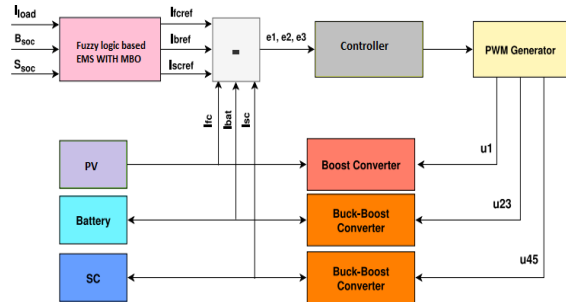

Fig 4: Control design and energy management of PV-EV using fuzzy logic.

The inputs and outputs along with their respective membership functions have been implemented as follows:

Input 1: Load current

The output power of the PV-HEV depends on the load current, which is categorized into four membership functions: negative, low, medium, and high. During negative load conditions, the fuel cell is inactive, and the battery and supercapacitor recover regenerative braking energy and operate in charging mode based on their SoC.

Input 2: State of charge of battery

Battery behaves as an auxiliary source and the reference battery current provided by the EMU depends upon the SoC of the battery which has been divided into three membership functions low, medium and high.

Input 3: State of charge of super capacitor

The reference supercapacitor (SC) current generated by the energy management unit (EMU) is based on the SC state of charge (SoC). During startup and transient conditions, when the PV source cannot meet peak power demands, the SC instantly discharges to supply the required power peak. The SoC of the SC is classified into three membership functions: low, medium, and high.

4. Fuzzy Logic Control System

Fuzzy logic control (FLC) is widely used for controlling highly nonlinear and ill-defined systems where conventional control methods are less effective. It mimics human reasoning by computing control actions from observed system states without requiring an exact mathematical model. By processing inputs as

continuous logical variables between 0 and 1, FLC provides robust and flexible control for complex applications. The basic control problem is given as follows.

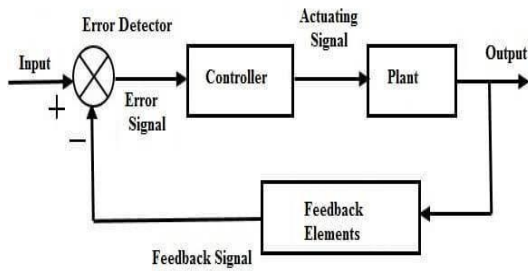

Fig 5: Closed Loop Control System

In a closed-loop control system, the output is regulated using an error signal that represents the difference between the actual and desired responses. A controller or compensator is included in the feedback loop to improve system accuracy, stability, and dynamic performance. In this setup, the fuzzy logic controller makes control decisions using IF-THEN rules based on inputs such as error and change in error, enabling effective handling of uncertainties and nonlinearities for smoother and adaptive control.

Result And Discussion

1. Simulation Output

The proposed/ designed controller has been simulated and verified using MATLAB/ Simulink under varying load conditions. The main objective of the proposed framework is the DC bus voltage regulation and to control the current flow by generating reference current for the power sources. The simulation results confirm effective voltage regulation and reliable energy management.

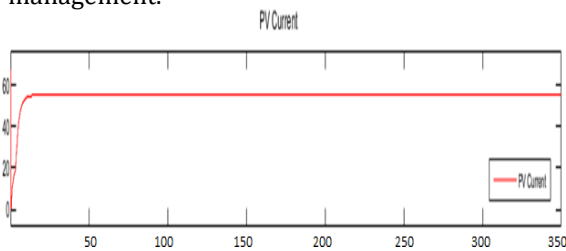

Fig 6: Output current waveform of solar PV array

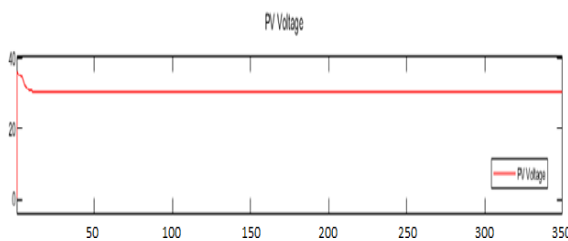

Fig 7: Output voltage waveform of solar PV array

Fig. 6 and Fig. 7 illustrates the experimental time current and voltage time response of PV. The Photovoltaic current in Fig. 6 achieves the maximum value of 55 A at 20 s. The PV voltage Fig. 7 varies according to the current imposed on it. It is also clear that the PV has a slow behaviour compared to the SC.

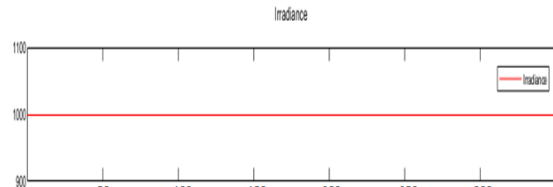

Fig 8: Irradiance waveform of solar PV

Figure 8 shows Irradiance waveform of solar PV. Solar irradiance (SI) is the power per unit area (watt per square metre, W/m²), received from the Sun in the form of electromagnetic radiation as reported in the wavelength range of the measuring instrument. Total Solar Irradiance (TSI) is a measure of the solar power over all wavelengths per unit area incident on the Earth's upper atmosphere. It is measured perpendicular to the incoming sunlight.

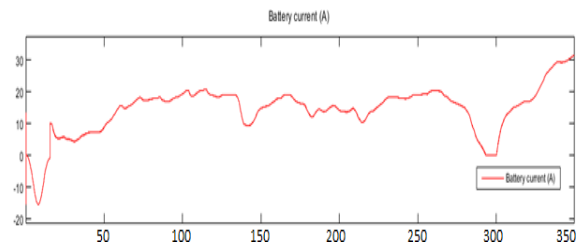

Fig 9: Output current waveform of battery

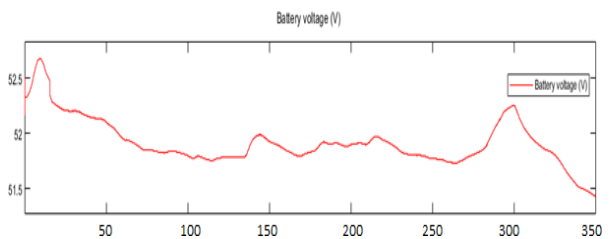

Fig 10: Output voltage waveform of battery

The curves in Fig. 9 and fig. 10 represent the battery current and voltage. From Fig. 3.4 one can notice battery voltage will vary between 51V and 52 A, which is almost constant.

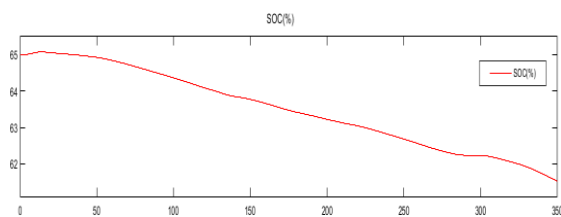

Fig 11: state of charge waveform of battery

Fig. 11 presents the variation in the SOC of the battery under different cycle conditions and operation modes. The SOC can be maintained at about 65 %, which effectively realizes the effect at the charge sustaining stage, and the SOC performance under the operation mode is the most stable. The stability of the SOC under different operation modes is analyzed based on the average SOC of the battery at the charge sustaining stage.

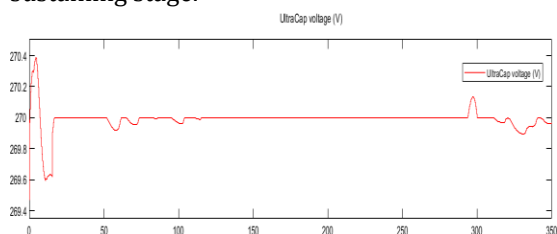

Fig 12: Output voltage waveform of super capacitor

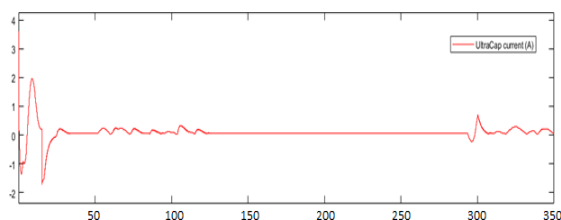

Fig 13: Output current waveform of super capacitor

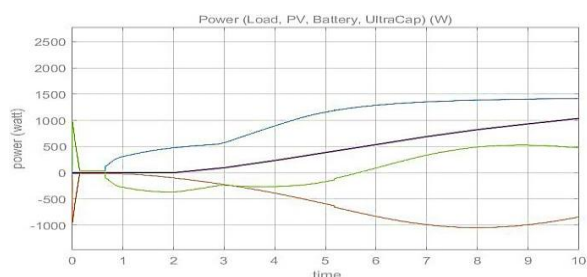

Fig 14: Output power of load, PV, Battery super capacitor

Fig. 14 the load power PLP_LPL is supplied by the combined contribution of PV power PPVP_{PV}PPV, battery power PBATP_{BAT}PBAT, and SC power PSCP_{SC}PSC throughout the operating period.

The PV power remains positive with a nearly smooth profile. The traction power reaches 1400 W, corresponding to the scaled real traction limit of 12 kW (1/60 scale). The battery supports the PV during conditions such as startup, while the SC handles energy absorption and supply during transient phases.

Conclusion

The implementation of hybrid and intelligent fuzzy logic control in MATLAB/Simulink enhances EV charging performance by optimally integrating solar PV with a hybrid energy storage system of batteries and super capacitors. The fuzzy logic controller dynamically manage power flow based on state of charge, improving charging efficiency, system stability, and battery lifespan while reducing dependence on the utility grid.

The simulation results confirm that fuzzy-based intelligent control enables faster charging while maintaining voltage and current within safe limits, ensuring reliable operation. This hybrid approach offers a sustainable and adaptive solution for next-generation EV charging, and MATLAB/Simulink validation highlights its feasibility and scalability for real-world applications.

References

Arian Zahedmanesh;Kashem M. Muttaqi;Danny Sutanto, 2021, "A Cooperative Energy Management in a Virtual Energy Hub of an Electric Transportation System Powered by PV Generation and Energy Storage" IEEE Transactions on Transportation Electrification, Vol 7, No. 3, pp. 1123 – 1133

Aqeel Ur Rahman, Syeda Shafia Zehra, Iftikhar Ahmad, Hammad Armghan, 2021, Fuzzy supertwisting sliding mode-based energy management and control of hybrid energy storage system in electric vehicle considering fuel economy, Journal of Energy Storage, Volume 37, 102468.

B. A. Taye and N. B. D. Choudhury, "Adaptive filter based method for hybrid energy storage system management in DC microgrid," e-Prime-Advances Electr. Eng. Electron. Energy, vol. 5, 2023, Art no. 100259.

Chunhua Zheng;Weimin Li;Quan Liang, 2018, "An Energy Management Strategy of Hybrid Energy Storage Systems for Electric Vehicle Applications" IEEE Transactions on Sustainable Energy, Vol. 9, No. 4

Christoforos Chatzikomis;Aldo Sornioti;Patrick

Gruber;Mattia Zanchetta;Dan Willans;Bryn Balcombe, "Comparison of Path Tracking and Torque-Vectoring Controllers for Autonomous Electric Vehicles"IEEE Transactions on Intelligent Vehicles, Vol. 3, No. 4, 2018

F. C. Ali, N. A. Bin Rahmat, V. K. A/L Ramachandaramurthy, and A. J. Humaidi, "Energy and battery management systems for electrical vehicles: a comprehensive review & recommendations," Energy Exploration & Exploitation, pp. 1–32, 2024.

G. Kannayeram, N.B. Prakash, R. Muniraj,2020, Intelligent hybrid controller for power flow management of PV/battery/FC/SC system in smart grid applications, International Journal of Hydrogen Energy, Volume 45, Issue 41, Pages 21779- 21795.

Hrvoje Novak;Vinko Lešić;Mario Vašak, 2019, "Hierarchical Model Predictive Control for Coordinated Electric Railway Traction System Energy Management" IEEE Transactions on Intelligent Transportation Systems, Vol. 20, No. 7, pp. 2715 – 2727

1zhaoxi liu;Qiuwei Wu;Mohammad Shahidehpour;Canbing Li;Shaojun Huang;Wei Wei, 2019, "Transactive Real-Time Electric Vehicle Charging Management for Commercial Buildings With PV On-Site Generation" IEEE Transactions on Smart Grid, Vol. 10, No. 5, pp. 4939 – 4950

Junjie Hu;Huayanran Zhou;Yang Li;Peng Hou;Guangya Yang, "Multi-time Scale Energy Management Strategy of Aggregator Characterized by Photovoltaic Generation and Electric Vehicles" Journal of Modern Power Systems and Clean Energy, Vol. 8, No. 4, 2020

J. Engelhardt, J. M. Zepter, T. Gabderakhmanova, and M. Marinelli, "Energy management of a multi-battery system for renewable-based high power EV charging," ETransportation, vol. 14, 2022, Art no. 100198

Kyaw Hein;Yan Xu;Gary Wilson;Amit K Gupta, 2021, "Coordinated Optimal Voyage Planning and Energy Management of All-Electric Ship

With Hybrid Energy Storage System" IEEE Transactions on Power Systems, Vol. 36, No. 3,pp. 2355 – 2365

Mahammad A. Hannan;Mohammad Faisal;Pin Jern Ker;Looe Hui Mun;Khadija Parvin;Teuku Meurah Indra Mahlia;Frede Blaabjerg, 2018, "A Review of Internet of Energy Based Building Energy Management Systems: Issues and Recommendations" IEEE Access, Vol. 6

M Huan Chen;Rui Xiong;Cheng Lin;Weixiang Shen, 2021, "Model predictive control based real-time energy management for hybrid energy storage system" CSEE Journal of Power and Energy Systems, Vol. 7, No. 4 Vehicle Charging in Commercial-building Prosumers" Journal of Modern Power Systems and Clean Energy, Vol. 9, No.5

Ningyuan Guo;Xudong Zhang;Yuan Zou;Basilio Lenzo;Guodong Du;Tao Zhang, "A Supervisory Control Strategy of Distributed Drive Electric Vehicles for Coordinating Handling, Lateral Stability, and Energy Efficiency" IEEE Transactions on Transportation Electrification, Vol. 7, No. 4, pp. 2488 – 2504, Dec.2021

N. Narasimhulu, R. S. R. Krishnam Naidu, P. Falkowski-Gilski, P. Bidare Divakarachari, and U. Roy, "Energy management for PV powered hybrid storage system in electric vehicles using artificial neural network and Aquila optimizer algorithm," Energies, vol. 15, p. 8540, 2022.

Rui Xiong;Yongzhi Zhang;Ju Wang;Hongwen He;Simin Peng;Michael Pecht, 2019, "Lithium-Ion Battery Health Prognosis Based on a Real Battery Management System Used in Electric Vehicles, IEEE Transactions on Vehicular Technology, Vol. 68, No. 5, pp. 4110 – 4121

R. Venkatasatish, C. Dhanamjayulu, 2022, Reinforcement learning based energy management systems and hydrogen refuelling stations for fuel cell electric vehicles: An overview, International Journal of Hydrogen Energy, Volume 47, Issue 64, Pages 27646-27670.