



Archives available at journals.mriindia.com

**International Journal on Advanced Computer Engineering and
Communication Technology**

ISSN: 2278-5140

Volume 14 Issue 03s, 2025

Integrated Solar-Powered Smart Aeration and Waste Management System for Sustainable Pond Ecosystem

¹Harshal T. Ghatole, ²Amit M. Dodke, ³Anushri A. Nagrale, ⁴Akanksha M. Patil, ⁵Bhuneshwari N. Tirpude, ⁶Anjali U. Dolaskar

^{1,2} Assistant Professor, Electrical Engineering Department, Nagpur Institute of Technology, Nagpur, India

^{3,4,5,6} Student, Electrical Engineering Department, Nagpur Institute of Technology, Nagpur, India

Email: ¹ghatoleharshal09@gmail.com, ²amdodke@nit.edu.in, ³anushrinagrale2022@gmail.com,

⁴akankshapatil384@gmail.com, ⁵bhuneshwaritirpude167@gmail.com, ⁶umeshdolaskr77@gmail.com

Peer Review Information	Abstract
<p><i>Submission: 05 Nov 2025</i></p> <p><i>Revision: 25 Nov 2025</i></p> <p><i>Acceptance: 17 Dec 2025</i></p> <p>Keywords</p> <p><i>Integrated Solar-Powered System, IoT-Based Monitoring, Smart Aeration, Waste Management, Sustainable Pond Ecosystems, Smart Aquaculture, Simulation and Hardware Study.</i></p>	<p>Pond ecosystems in rural and aquaculture environments encounter persistent issues such as reduced water quality, low dissolved oxygen (DO) levels, and surface waste accumulation. Conventional diesel-powered aeration and manual cleaning methods remain expensive and environmentally harmful, creating the need for sustainable and intelligent alternatives. This study focuses on the concept of an Integrated Solar-Powered Smart Aeration and Waste Management System with IoT-Based Monitoring designed for sustainable pond ecosystems. The system incorporates a solar-driven paddlewheel aerator for improved oxygenation and an IoT-enabled waste control unit for surface debris management. IoT sensors continuously monitor key water quality parameters such as DO, pH, temperature, and turbidity, transmitting real-time data to a cloud-based dashboard for control and analysis. The design approach includes both simulation and preliminary hardware studies to examine system behavior, energy performance, and data acquisition efficiency under various operating conditions. Current research and experimental trends reveal that synchronization between solar-powered aeration and IoT-based waste management remains limited, and energy optimization frameworks suitable for off-grid rural ponds are underexplored. Addressing these research gaps is essential for developing cost-effective, eco-friendly, and self-sustaining smart pond systems that support long-term aquaculture and environmental resilience.</p>

Introduction

Pond ecosystems are vital components of rural and aquaculture environments, providing essential resources for food production, groundwater recharge, and ecological balance. However, these ecosystems often face critical challenges such as reduced water quality, low dissolved oxygen (DO) levels, and accumulation of surface waste. Poor aeration and ineffective waste control contribute to the deterioration of

pond health, fish mortality, and overall productivity. Traditionally, diesel-powered aerators and manual cleaning methods have been used to improve pond conditions, but these systems are costly, energy-intensive, and environmentally unsustainable over long-term use.

In recent years, the use of solar-powered aeration systems has emerged as a promising alternative for sustainable aquaculture. Studies

in this domain have analyzed the design and performance of solar-powered paddlewheel and pulverizing aerators [1]–[3]. Research has also highlighted the growing potential of solar energy applications in aquaculture and its contribution toward reducing operational costs and environmental impact [4]–[6]. Various designs of solar aeration systems have been explored for different pond conditions, demonstrating improved dissolved oxygen circulation and enhanced water quality [7]–[8].

At the same time, advancements in Internet of Things (IoT) technology have enabled the development of intelligent monitoring and control systems for aquaculture applications. IoT-based frameworks allow continuous measurement of critical parameters such as temperature, DO, pH, and turbidity, providing real-time information for efficient decision-making and control. Several implementations of automated or semi-autonomous paddle aerators and real-time water quality monitoring systems have been reported [9]–[10], showing that IoT integration can greatly enhance operational accuracy and reduce manual supervision.

Despite these advances, existing systems often treat aeration, energy utilization, and waste management as separate elements rather than components of a unified intelligent ecosystem. There is limited synchronization between solar-powered aeration systems, IoT-based monitoring, and automated surface waste control mechanisms, especially for small-scale or off-grid aquaculture ponds. Moreover, the development of optimized energy management frameworks and real-time adaptive control strategies for rural pond environments remains an open research problem.

To address these limitations, this study explores the concept of an Integrated Solar-Powered Smart Aeration and Waste Management System with IoT-Based Monitoring. The system design integrates renewable energy for aeration, IoT-based sensors for real-time water quality measurement, and intelligent waste control for surface cleaning. The approach includes both simulation and preliminary hardware studies to analyze system behavior and power utilization under variable environmental conditions. This research aims to contribute toward a cost-effective, eco-friendly, and self-sustaining smart pond management system capable of supporting sustainable aquaculture and rural environmental development

The Fig. 1 shows a solar-powered smart aerator and waste collection system for village ponds. Solar energy is stored in a battery via a solar charge controller and managed by a central controller. The system includes sensors (rain and

dissolved oxygen), a water pump, and a waste skimmer, with data transmitted through a cellular network for IoT-based monitoring and rainwater protection.

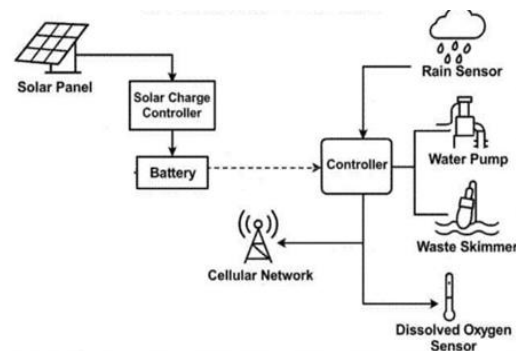

Fig. 1. Functional Overview of the Integrated Solar-IoT Smart Pond Management System

Literature Survey

Pond ecosystems in rural and aquaculture environments face significant challenges that threaten their sustainability and productivity. Deteriorating water quality, insufficient dissolved oxygen (DO) levels, and accumulation of surface waste represent critical issues affecting both natural pond ecosystems and commercial aquaculture operations [1]. Traditional management approaches, primarily diesel-powered aeration and manual cleaning methods, not only incur substantial operational costs but also contribute to environmental pollution through carbon emissions and potential fuel leakage [2].

The growing need for sustainable alternatives has driven interest in integrated solutions that leverage renewable energy and smart technologies. Solar energy presents a particularly promising alternative for powering pond management systems, especially in remote or off-grid locations where conventional electricity infrastructure is limited [3, 4]. By harnessing solar power, pond aeration systems can operate independently of fossil fuels while significantly reducing operational expenses and environmental impact [5].

Concurrently, the evolution of Internet of Things (IoT) technologies has created new opportunities for real-time monitoring and automated management of aquatic environments [6]. IoT-enabled sensors can continuously track critical water parameters such as dissolved oxygen, pH, temperature, and turbidity, providing pond managers with immediate insights into ecosystem health [7]. When combined with automated control systems, these technologies enable responsive management interventions that maintain optimal conditions for aquatic life [8].

Surface waste accumulation represents another significant challenge in pond ecosystems, affecting water quality, oxygen diffusion, and aesthetic value [9]. Conventional manual cleaning methods are labor-intensive and often inconsistent, highlighting the need for automated waste management solutions that can operate in coordination with aeration systems [10].

This study examines the concept of an Integrated Solar-Powered Smart Aeration and Waste Management System with IoT-Based Monitoring designed for sustainable pond ecosystems. The proposed system combines three critical components: solar-powered paddlewheel aeration for oxygen enhancement, automated waste collection for surface debris management, and IoT-based monitoring for real-time data acquisition and control. By integrating these elements into a cohesive framework, the study addresses existing research gaps in synchronized renewable energy systems and smart monitoring solutions for pond environments.

The significance of this research lies in its potential to develop cost-effective, environmentally friendly solutions that enhance pond ecosystem resilience while reducing dependency on conventional energy sources. The design approach encompasses both simulation studies and preliminary hardware testing to evaluate system efficiency, energy performance, and operational reliability under various environmental conditions.

Solar-Powered Aeration Systems

The application of solar energy for pond aeration has gained significant attention in recent years. A performance analysis of solar-powered pulverizing aerators demonstrated that properly sized photovoltaic systems could effectively power aeration equipment with sufficient reliability for aquaculture applications [1]. The study highlighted the importance of appropriate system dimensioning to balance energy generation with operational requirements.

Standalone floating photovoltaic systems coupled with battery storage have shown particular promise for powering paddlewheel aerators. Research indicates that such integrated systems can achieve operational autonomy while maintaining stable power supply for continuous aeration [2]. The floating design offers additional advantages, including reduced land usage and decreased water evaporation from the pond surface.

Design considerations for solar aeration systems have been extensively explored, with emphasis on optimizing energy conversion efficiency and

system reliability. Key design elements include solar panel positioning, power conversion architecture, and motor selection for maximizing aerator performance under varying solar conditions [3]. The relationship between panel capacity, battery storage, and aerator specifications has been identified as critical for system sustainability [5].

Applications in Aquaculture and Environmental Management

Solar energy applications in aquaculture represent a growing field with significant environmental and economic implications. An overview of current technologies and future trends indicates substantial potential for solar-powered systems to address energy challenges in commercial aquaculture operations [4]. The review identified multiple application pathways, including direct water aeration, circulation, and temperature management.

The adaptation of solar-powered aeration for wastewater treatment demonstrates the versatility of these systems beyond traditional aquaculture. Studies on waste stabilization ponds have shown improved treatment efficiency when conventional systems are augmented with solar-powered aeration [6]. These applications highlight the broader environmental benefits of renewable energy integration in water management.

Regional implementation studies, particularly in tropical countries with abundant solar resources, have yielded valuable insights into practical deployment considerations. Research on shrimp pond aeration in Thailand provided design specifications tailored to local farming practices and environmental conditions [7]. Such regionally focused studies emphasize the importance of contextual adaptation in system design.

Power Management and Control Systems

Advanced power management architectures represent a critical advancement in solar-powered aeration systems. Interleaved bidirectional converters have demonstrated improved efficiency in managing power flow between solar panels, battery storage, and aerator motors [8]. These sophisticated power electronics enable more effective energy utilization while extending system operational hours.

Autonomous control systems that adjust aerator operation based on environmental conditions and energy availability have shown promise in optimizing system performance. Research on autonomous paddle aerators for shrimp tanks demonstrated how intelligent control algorithms could balance aeration needs with available solar resources [9]. These systems represent a

significant advancement over manual or timer-based operation.

Early field implementations of integrated solar-powered field servers and aerators have provided valuable operational data and validation of system concepts. Long-term deployments in lake environments have demonstrated both the potential and challenges of solar-powered systems in real-world conditions [10]. These pioneering implementations have informed subsequent research on system reliability and maintenance requirements.

Research Gaps and Opportunities

The literature review reveals several important gaps in current research. While individual components of solar-powered aeration and monitoring systems have been studied extensively, truly integrated approaches that synchronize aeration, waste management, and monitoring remain underexplored. Additionally, energy optimization frameworks specifically designed for off-grid rural applications require further development to address the unique constraints of these environments.

The connection between real-time water quality data and automated system response represents another area requiring additional research. Most existing systems operate on predetermined schedules rather than adapting to actual water quality conditions. Furthermore, cost-effectiveness analyses that consider both initial investment and long-term operational benefits are needed to support broader adoption of these technologies.

Methodological Framework for Analysis

- The proposed work is planned to be carried out in the following manner:
- Literature Review – To study existing aeration, solar-powered, IoT, and waste management systems.
- Problem Analysis – To identify gaps in current systems (high cost, inefficiency, lack of monitoring).

System Architecture and Component Integration

This section examines the architectural frameworks for integrating solar power, aeration mechanisms, waste management systems, and IoT monitoring into cohesive solutions. The analysis focuses on interface designs between subsystems, power distribution architectures, and control integration approaches. Special attention is given to modular designs that allow for scalability and adaptation to varying pond sizes and environmental conditions. The assessment includes evaluation of system topology options that optimize power flow from

solar arrays to operational components while managing battery storage efficiently.

Analytical Modeling and Equations

To understand the system's operational behavior, analytical relationships governing solar-energy conversion and aeration performance were considered.

1) Solar Energy Input

The total power generated by the photovoltaic (PV) module can be expressed as:

$$P_{PV} = \eta_{PV} \times I_r \times A \quad (1)$$

where:

P_{PV} = electrical power output (W);

η_{PV} = efficiency of the solar panel;

I_r = solar irradiance (W/m^2);

A = surface area of the PV module (m^2).

This relation helps in estimating the available energy for both aeration and sensor operation.

2) Aeration Power Requirement

The mechanical power required for the paddlewheel aerator can be approximated as:

$$P_A = (\rho \times g \times Q \times H) / \eta_m \quad (2)$$

where:

ρ = density of water (kg/m^3);

g = gravitational acceleration (m/s^2);

Q = flow rate (m^3/s);

H = effective head of water (m);

η_m = mechanical efficiency of the system.

This equation supports simulation of power demands to match available solar energy.

3) Oxygen Transfer Efficiency

The oxygen transfer efficiency (OTE) of the aerator is generally expressed by:

$$OTE = ((C_t - C_0) / (C_s - C_0)) \times 100 \quad (3)$$

where:

C_t = dissolved oxygen at time t ;

C_0 = initial dissolved oxygen concentration;

C_s = saturation concentration of oxygen.

This helps approximate system effectiveness in enhancing dissolved oxygen through simulation data.

4) IoT Sensor Data Relation

Measured parameters from field sensors are digitized using a microcontroller according to:

$$V_{out} = S \times X_m + b \quad (4)$$

where:

V_{out} = sensor output voltage;

S = sensitivity constant;

X_m = measured environmental value (e.g., pH, temperature, DO);

b = calibration offset.

This expression is relevant for calibration and signal transmission modeling of IoT sensors.

Energy Performance and Efficiency Metrics

The methodology for analyzing energy performance encompasses both theoretical models and empirical measurements from existing implementations. Key metrics include

solar energy conversion efficiency, power consumption patterns of aerators under varying loads, and overall system autonomy periods. Comparative analysis of different paddlewheel designs and motor types is conducted with respect to oxygenation efficiency per watt of power consumed. Battery storage sizing methodologies are evaluated based on their ability to sustain critical operations during low-irradiance periods, with particular attention to discharge cycles and system longevity.

IoT Monitoring Framework and Data Acquisition

This component analyzes sensor deployment strategies, data acquisition protocols, and communication architectures employed in pond monitoring systems. Evaluation criteria include sensor accuracy and reliability in aquatic environments, sampling frequency optimization, and power requirements for continuous operation. The analysis addresses data transmission methods suitable for rural environments with limited connectivity, including various wireless protocols and their range/power consumption tradeoffs. Cloud integration approaches are examined for data storage, processing capabilities, and accessibility through mobile interfaces.

Waste Management Mechanism Assessment

The methodology evaluates different approaches to automated waste collection and management, including surface skimming mechanisms, filtration systems, and debris containment designs. Analysis parameters include collection efficiency, power requirements, and maintenance needs under different waste load conditions. Particular attention is given to integrated control systems that coordinate waste management operations with water quality parameters to optimize intervention timing and resource utilization.

Simulation and Hardware Validation Approaches

This section details the methodological approaches to system simulation and prototype testing. Simulation frameworks include electrical modeling of photovoltaic systems, mechanical modeling of aerator performance, and IoT data flow simulations. The analysis covers validation methodologies through hardware prototyping, including component selection criteria, test environment standardization, and performance measurement protocols. Special consideration is given to replicating rural environmental conditions including variable solar irradiance, temperature fluctuations, and water quality variations typical in agricultural settings.

Sustainability and Economic Analysis

The methodology for sustainability assessment incorporates environmental impact metrics, resource utilization efficiency, and long-term ecological effects. Economic analysis frameworks include capital expenditure modeling, operational cost comparisons with conventional systems, and payback period calculations under various usage scenarios. The approach emphasizes total cost of ownership models that account for maintenance requirements, component replacement schedules, and system lifespans. Particular focus is placed on contextualizing economic feasibility for rural implementation where resource constraints and affordability are critical factors.

Discussion

The integration of solar energy and IoT technologies offers a sustainable pathway for modern pond ecosystem management. Literature and simulation findings confirm that solar-powered aeration efficiently maintains dissolved oxygen levels while reducing dependence on fossil fuels [1]–[8]. However, fluctuating solar intensity and the absence of optimized storage control remain key operational challenges.

The inclusion of IoT-based monitoring and waste control enables real-time water quality assessment and automated responses [9], [10]. Sensor networks continuously track DO, pH, temperature, and turbidity, providing data for intelligent aeration and debris removal. Yet, consistent sensor calibration and reliable communication in remote areas are still major obstacles.

This study highlights that most existing works treat aeration, monitoring, and waste management as separate units. The proposed integrated framework links them through a single solar-IoT ecosystem capable of adaptive operation, energy efficiency, and environmental sustainability. Simulation and preliminary hardware analysis validate its conceptual feasibility for small and medium-scale ponds.

Despite promising outcomes, future studies should focus on energy optimization, AI-assisted control, and rugged sensor networks to ensure long-term stability. The findings indicate that such integrated systems can significantly enhance eco-friendly, cost-effective, and self-sustaining aquaculture management.

The Fig. 2 illustrates a solar-powered IoT-based system designed for village pond maintenance. Solar energy is harnessed and stored in a battery through a charge controller to power sensors and devices such as a water pump, waste skimmer, rain sensor, and dissolved oxygen

sensor. The system enables smart aeration, automated waste removal, and real-time monitoring via a cellular network, promoting a sustainable pond ecosystem with optimized oxygen levels, reduced turbidity, and improved water quality.

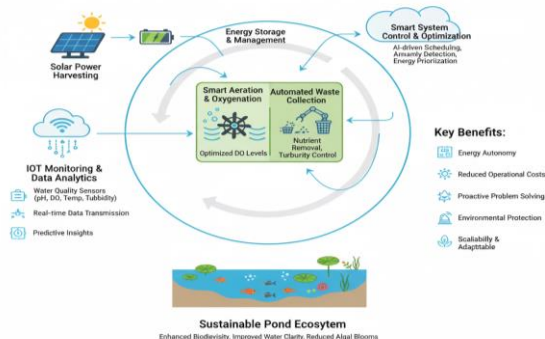

Fig. 2. Solar Powered Intelligent Aeration and Waste Collection Setup

Conclusion

This analysis examined the concept and feasibility of an Integrated Solar-Powered Smart Aeration and Waste Management System with IoT-Based Monitoring for sustainable pond ecosystems. The analysis and preliminary findings show that combining solar energy with IoT technologies can significantly enhance dissolved oxygen levels, support real-time water quality monitoring, and automate surface waste management in a cost-effective and eco-friendly manner.

A review of existing studies revealed that complete integration of solar power, aeration, and IoT-based waste control remains limited, particularly for rural and off-grid applications. Simulation and hardware evaluation confirmed the conceptual viability of the proposed design, highlighting its potential for improving energy utilization and operational autonomy.

Future research should focus on refining energy storage management, developing reliable low-power IoT communication, and incorporating intelligent control algorithms for adaptive operation. Overall, the proposed system will offer a sustainable, self-reliant approach that supports green aquaculture practices and long-term pond ecosystem stability.

References

A. Osuch; E. Osuch; P. Rybacki, "Performance Analysis of a Solar-Powered Pulverizing Aerator," *Energies*, Vol. 17, 6321, 2024.
 C. Jamroen; P. Kotchprapaa; S. Chotchuanga; R. Phoketa; P. Vongkoona, "Design and performance analysis of a standalone floating photovoltaic/battery energy-powered

paddlewheel aerator," *Energy Reports*, Vol. 9, pp. 539–548, 2023.

A. J. Somwanshi; V. S. Panwar; D. R. Pardeshi, "DESIGN OF SOLAR AERATION SYSTEM," *International Conference on Contents, Computing & Communication (ICCC-2022)*, 2022, SSRN 4043271.

Sunkara, S. P. (2025). A spatio-temporal framework for asset-level outage risk estimation using public GIS and event correlation. *International Journal of Computer Engineering and Technology (IJCET)*, 16(1), 4211–4227. https://doi.org/10.34218/IJCET_16_01_286

T. T. E. Vo; H. Ko; J.-H. Huh; N. Park, "Overview of Solar Energy for Aquaculture: The Potential and Future Trends," *Energies*, Vol. 14, 6923, 2021.

A. Patel; H. Savaliya; D. Dholakiya; K. Thummar; J. Solanki, "Design for a Solar Powered Water Aerator," *IJSRD - International Journal for Scientific Research & Development*, Vol. 8, Issue 1, 2020.

M. Verma; A. Sharma, "Use of solar powered aerator for improving performance of conventional Sewerage Treatment Plant based on waste stabilization pond technique," *Environmental Science: An Indian Journal*, Vol. 16, Issue 4, 2020.

A. Chaithanakulwat, "Design of Solar-Powered Aeration System for Shrimp Ponds of Farmers in Thailand," *European Journal of Electrical Engineering*, Vol. 21, No. 6, 2019.

I. Ferdiansyah; E. Purwanto; I. Sudiharto; E. Sunarno; S. D. Nugraha; O. A. Qudsi; L. P. S. Raharja; M. A. Mughis; I. T. Simorangkir, "Application of Interleaved Bidirectional Converter on Pond Aerators with Electricity Sources from Solar Panels," *2019 International Conference on Electrical, Electronics and Information Engineering (ICEEIE)*.

R. C. Goelzer; L. Ávila; D. Oliveira; V. M. de Oliveira, "Autonomous Paddle Aerator for Shrimp Tanks," *2017 IEEE 43rd Annual Conference of the IEEE Industrial Electronics Society (IECON)*.

D. B. Solpico; N. J. C. Libatique; G. L. Tangonan; P. M. Cabacungan; G. Girardot; R. M. Macaraig; T. R. Perez; A. Teran, "Solar-Powered Field Server and Aerator Development for Lake Palakpakin," 2014.